

QUARTER BAFFLES INSTALL GUIDE

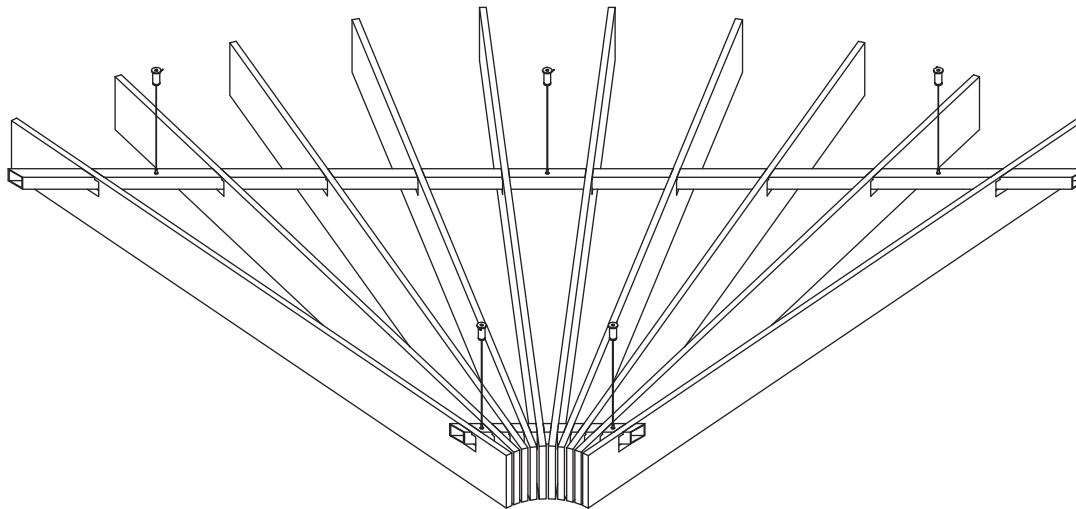

www.crownsurfacesolutions.com
e: info@crownsurfacesolutions.com
p: 416.245.2900

QUARTER BAFFLES ASSEMBLY

1) Thread baffles onto the square mounting beams provided.

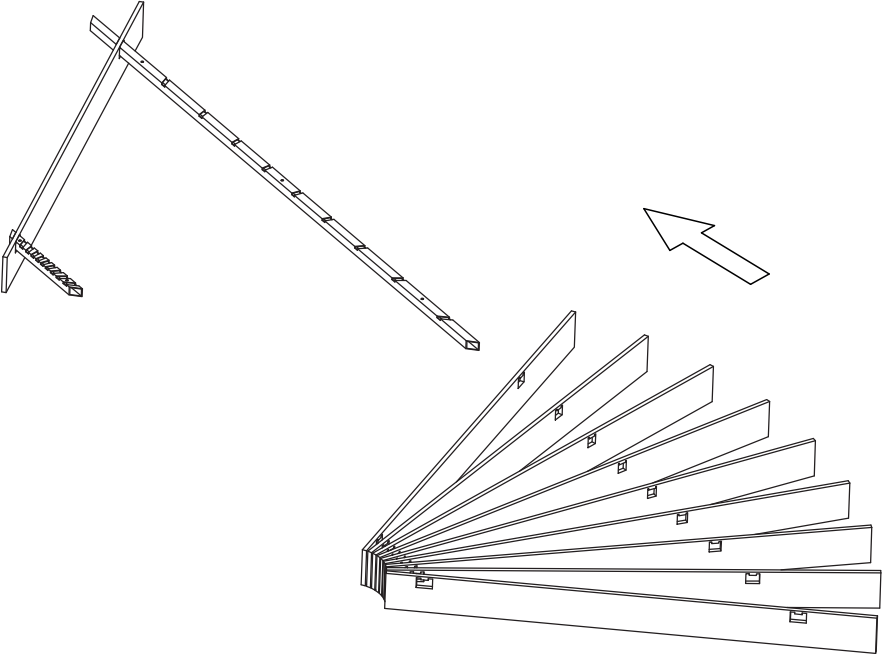

STEP 1

2) Lock each baffle into position by pushing downwards as shown.

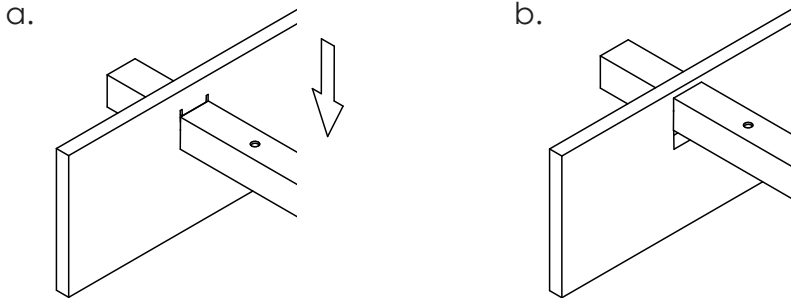

3) Baffle assembly is complete

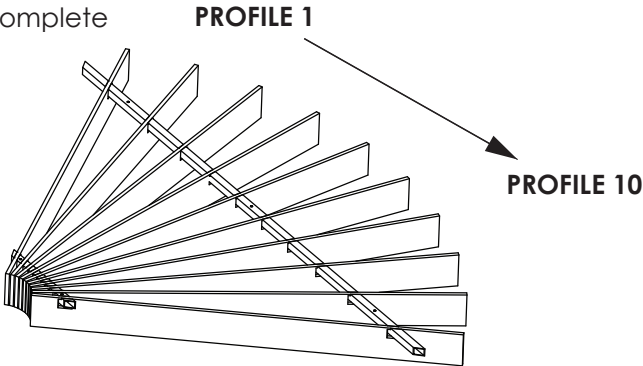

STEP 2 & 3

QUARTER BAFFLES SUSPENSION METHOD

4) Place baffle assembly up to ceiling in desired location. Mark position of **6 off** through holes which correspond to the mounting holes.

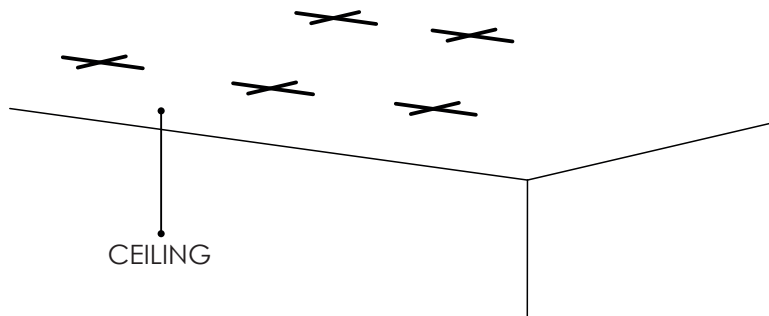

5) Consulting the “**Baresque Systems Fixing Directory**”, select the appropriate fixing method for your substrate & install **6 off** ‘hanger heads’. **Please note, screws are not supplied.**

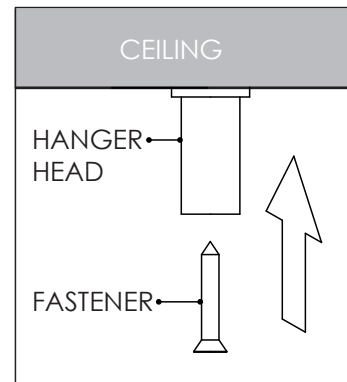

STEP 4 & 5

6) Thread wires through mounting holes in square mounting beams.

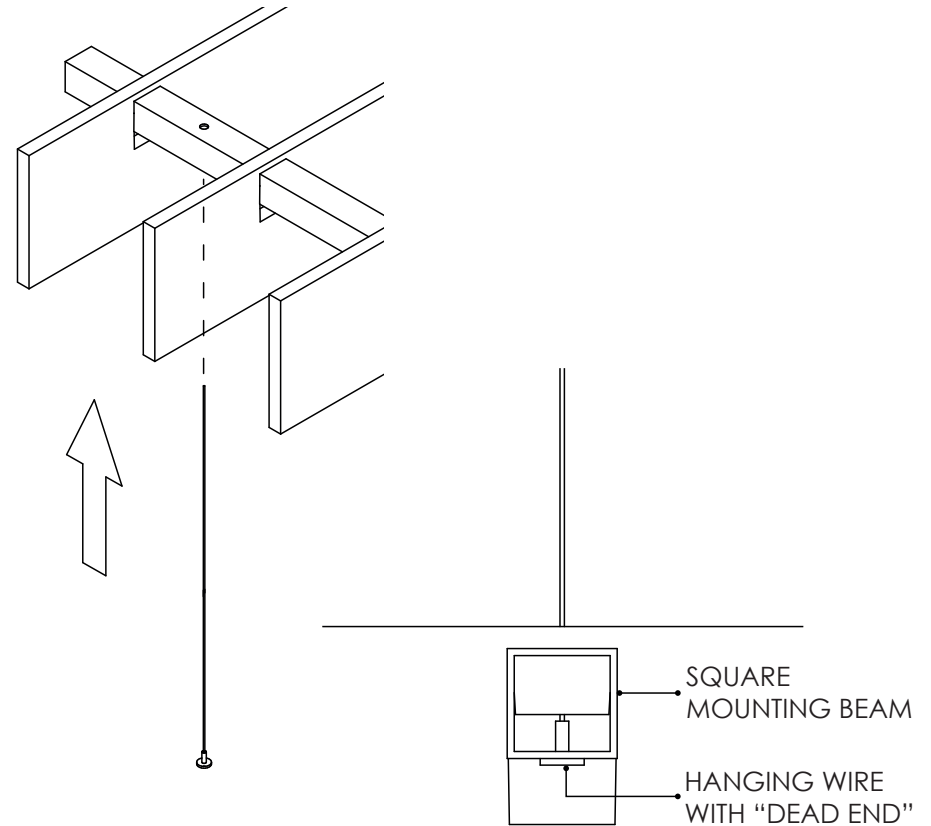

STEP 6

**PLEASE NOTE: BAFFLE INSTALLATION
WILL REQUIRE 2 PEOPLE.**

QUARTER BAFFLES SUSPENSION METHOD

7) Feed top of wire through tip of 'wire adjuster' (as shown). Push button (shown in grey) to adjust wire length. Release the button to lock in place.

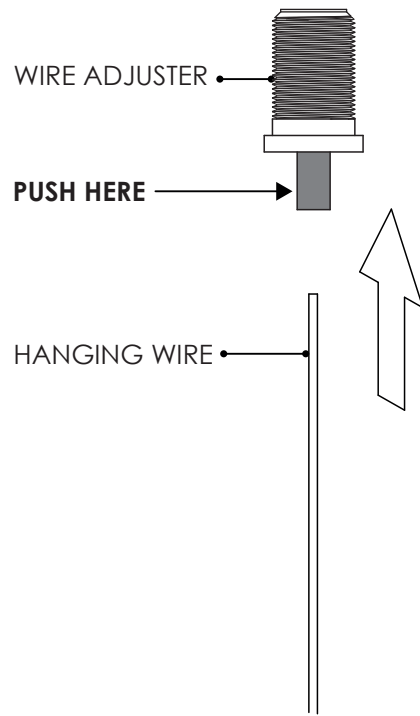

STEP 7

8) Feed wire through hole in the side of 'hanger head'. Screw 'wire adjuster' into 'hanger head'. When all wires are in place, adjust lengths so baffle assembly hangs level.

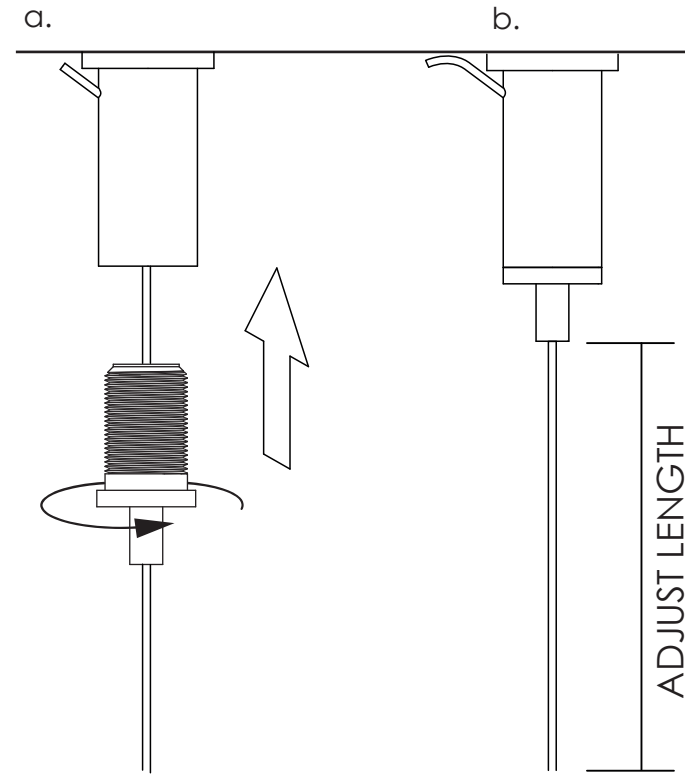

STEP 8

**PLEASE NOTE: BAFFLE INSTALLATION
WILL REQUIRE 2 PEOPLE.**

QUARTER BAFFLES
SUSPENSION METHOD

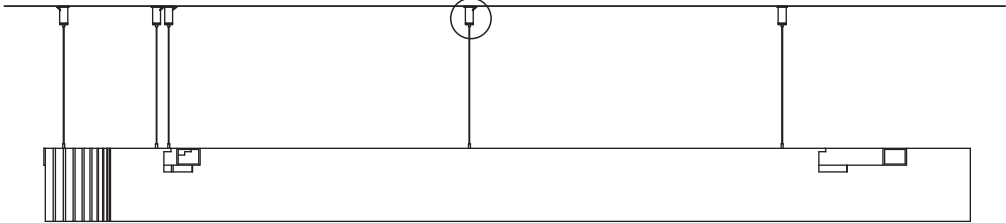

SIDE VIEW

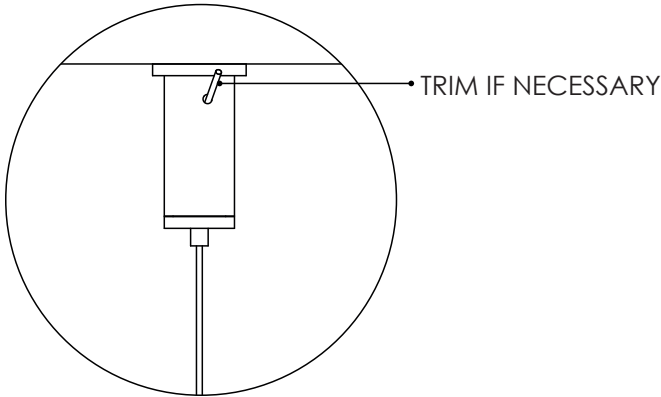

DETAIL VIEW

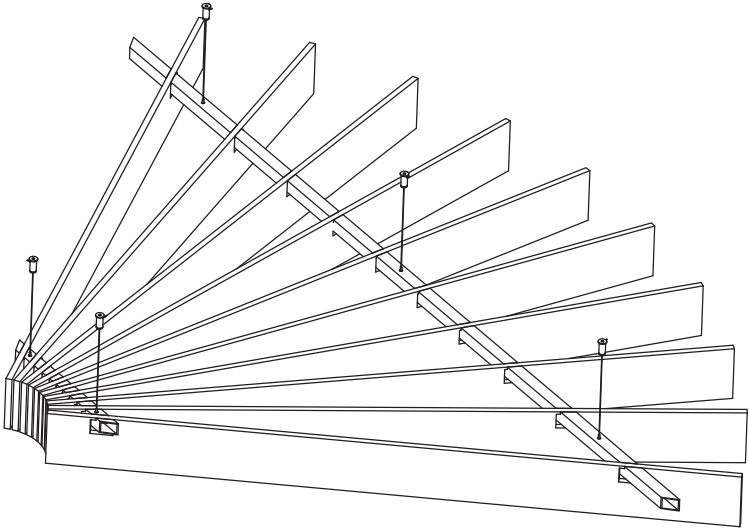

COMPLETED INSTALL

**PLEASE NOTE: BAFFLE INSTALLATION
WILL REQUIRE 2 PEOPLE.**

QUARTER BAFFLES

CONNECTOR & CAPPING DETAIL

CONNECTOR DETAIL

To connect multiple baffle assemblies together, insert connectors into open ends of square mounting beams and push assemblies together as shown.

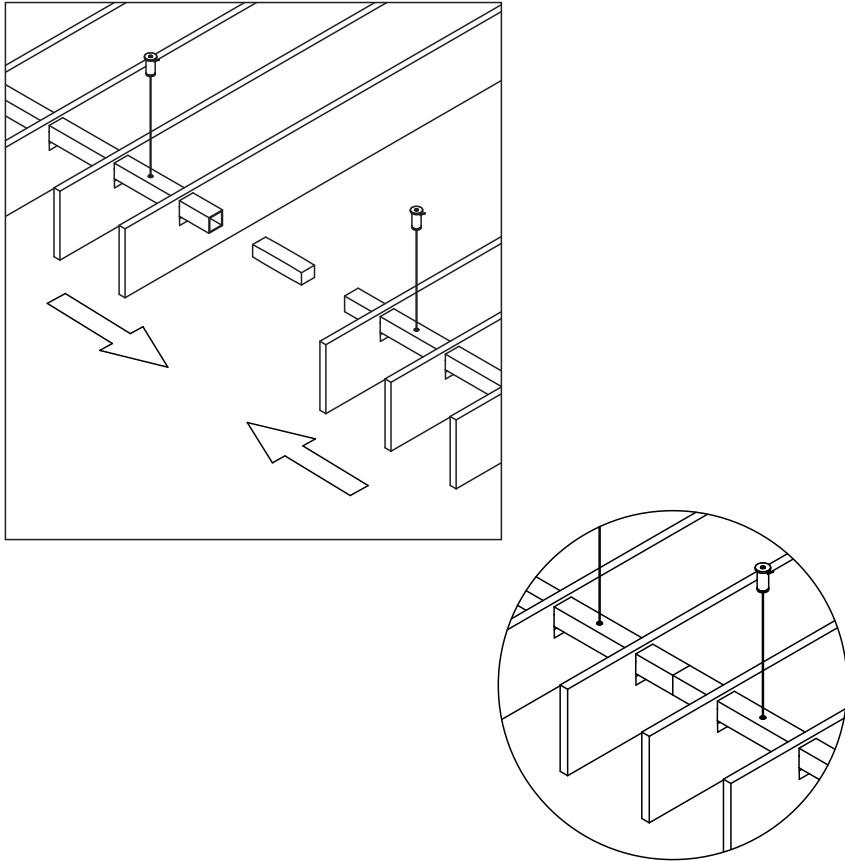

CAPPING DETAIL

To cap ends of baffle assembly- insert end caps provided as shown.

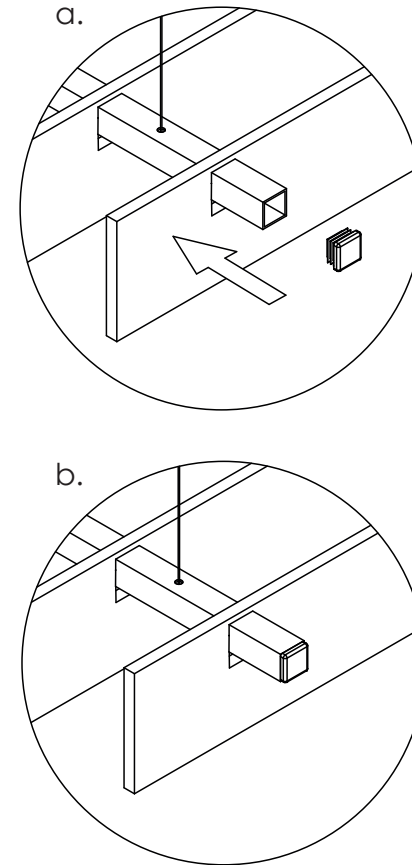

**PLEASE NOTE: BAFFLE INSTALLATION
WILL REQUIRE 2 PEOPLE.**

QUARTER BAFFLES PARTS

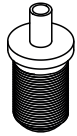

5x
WIRE ADJUSTER

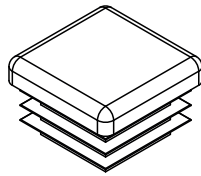

4x
END CAPS

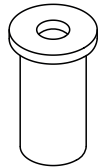

5x
HANGER HEAD

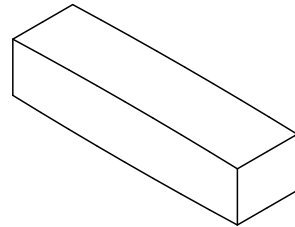

2x
CONNECTORS

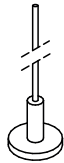

5x
HANGING WIRE

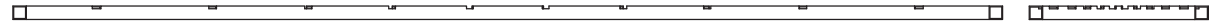

2x SQUARE MOUNTING BEAM one short and one long



PROFILE 1



PROFILE 2



PROFILE 3



PROFILE 4



PROFILE 5



PROFILE 6
same as profile 5



PROFILE 7
same as profile 4



PROFILE 8
same as profile 3



PROFILE 9
same as profile 2



PROFILE 10
same as profile 1

QUARTER BAFFLES
LAYOUT EXAMPLES
PLAN VIEW

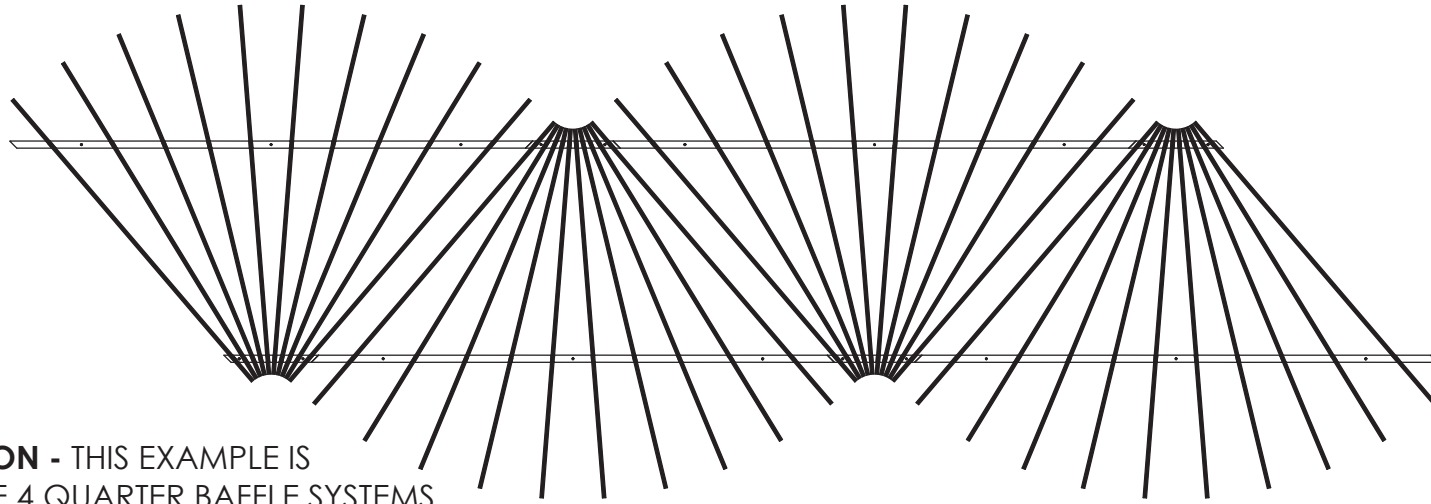

SNAKE OPTION - THIS EXAMPLE IS
MADE UP OF 4 QUARTER BAFFLE SYSTEMS

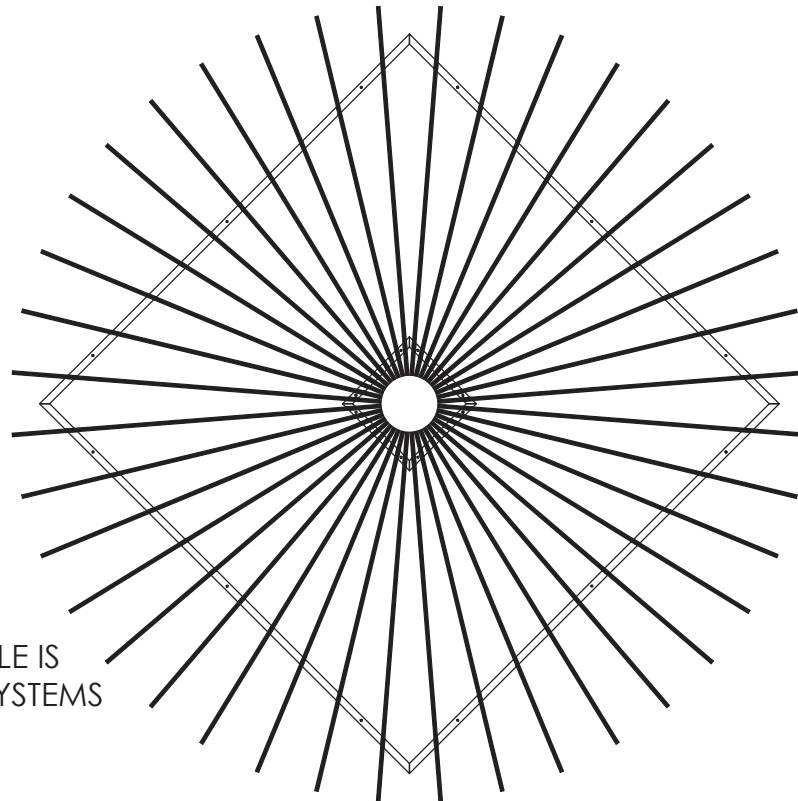

FULL CIRCLE OPTION - THIS EXAMPLE IS
MADE UP OF 4 QUARTER BAFFLE SYSTEMS